



**MODELLO / MODEL**  
**TEL260FBO**

**INFORMAZIONI TECNICHE / TECHNICAL INFORMATION**

Massa base unità (corsa zero) Unit's base mass (zero stroke)	[Kg]	67,5
Massa lineare unità Unit's linear mass	[Kg/100 mm]	1,32
Massa carro secondo sfilo (corsa zero) Carriage's mass second extension (zero stroke)	[Kg]	15,5
Massa carro secondo sfilo (x 100 mm corsa) Carriage's mass second extension (x 100 mm stroke)	[Kg/100mm]	0
Massa primo sfilo (corsa zero) Mass first extension (zero stroke)	[Kg]	17,5
Massa primo sfilo (x 100 mm corsa) Mass first extension (x 100 mm stroke)	[Kg/100mm]	1,32
Velocità massima* Maximum velocity	[m/s]	4
Ripetibilità a vuoto Unloaded repeatability	[mm]	±0,15
Azionamento primo sfilo - secondo sfilo Drive first extension - second extension	Cinghia/Cinghia Belt/Belt	
Taglia cinghia primo sfilo Belt's size first extension		75 AT 10
Sviluppo puleggia Pulley's circumference	[mm/giro]	300

\* I valori sono da considerarsi indicativi.  
Prestazioni superiori sono possibili e vanno verificate col nostro ufficio tecnico.  
Values should be considered as an indication.  
Higher performance are possible. Please Contact our technical department.

\*\* Disponibile su richiesta classe precisione Q6.  
Available on request accuracy class Q6.

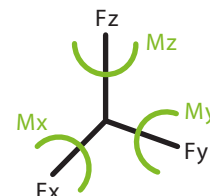
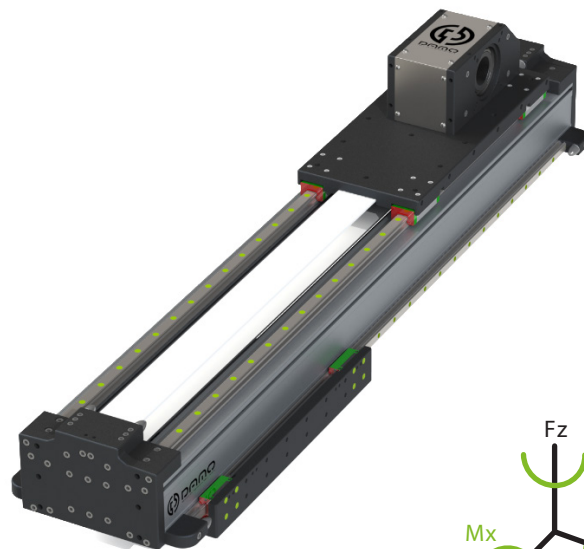

**CARICO MASSIMO AMMISSIBILE / MAXIMUM PERMISSIBLE LOAD**

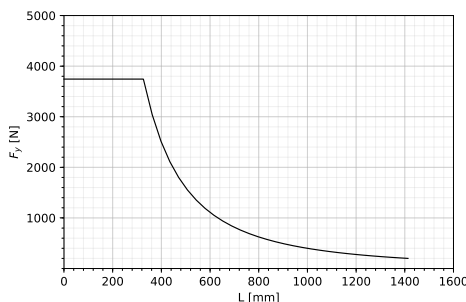
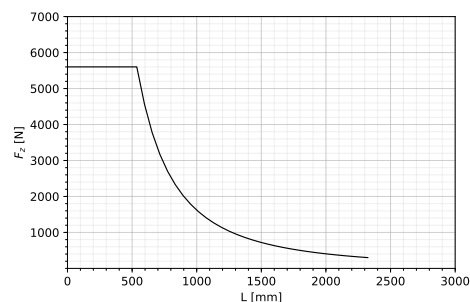

Sono rappresentati i carichi massimi applicabili in condizioni isostatiche, con vincolo rigido e carico all'estremità.  
Maximum load in an isostatic cantilever loaded condition.

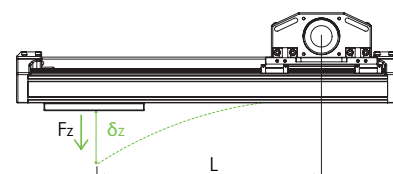

Accessori Accessories	Cinghia Belt	Vite Ball screw	Cremagliera Rack and pinion
① Riduttore Gearbox	x	x	x
② Kit assiale Axial kit	x	x	x
③ Calettatore Keyless Locking Device	x		x
④ Albero di torsione Torsion shaft	x		x
⑤ Carro aggiuntivo Additional carriage	x		x
⑥ Giunto elastico Elastic coupling	x		
⑦ Freno stazionamento Standing brake	x		
⑧ Elemento fissaggio/tassello Fastening/plug	x	x	x
⑨ Kit rinvio Transfer box	x	x	
⑩ Supporto sensore/Camma Sensor bracket/Cam	x	x	x

Le Unità Damo sono disponibili con una vasta gamma di accessori e optional specifici concepiti per facilitare la realizzazione e installazione di sistemi monoasse e multiasse.  
All Units are available with a wide range of accessories and specific options designed to simplify the construction and installation of single-axis and multi-axis systems.

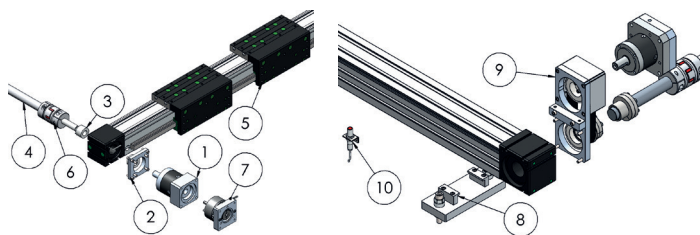

Si raccomanda di non superare i limiti dei grafici per non avere malfunzionamento dell'unità, peggioramento delle prestazioni o eccessiva usura.  
We recommend not to exceed the maximum values to avoid lower performance, a reduced reliability and a big wear of the components.



**DIMENSIONI / DIMENSIONS**

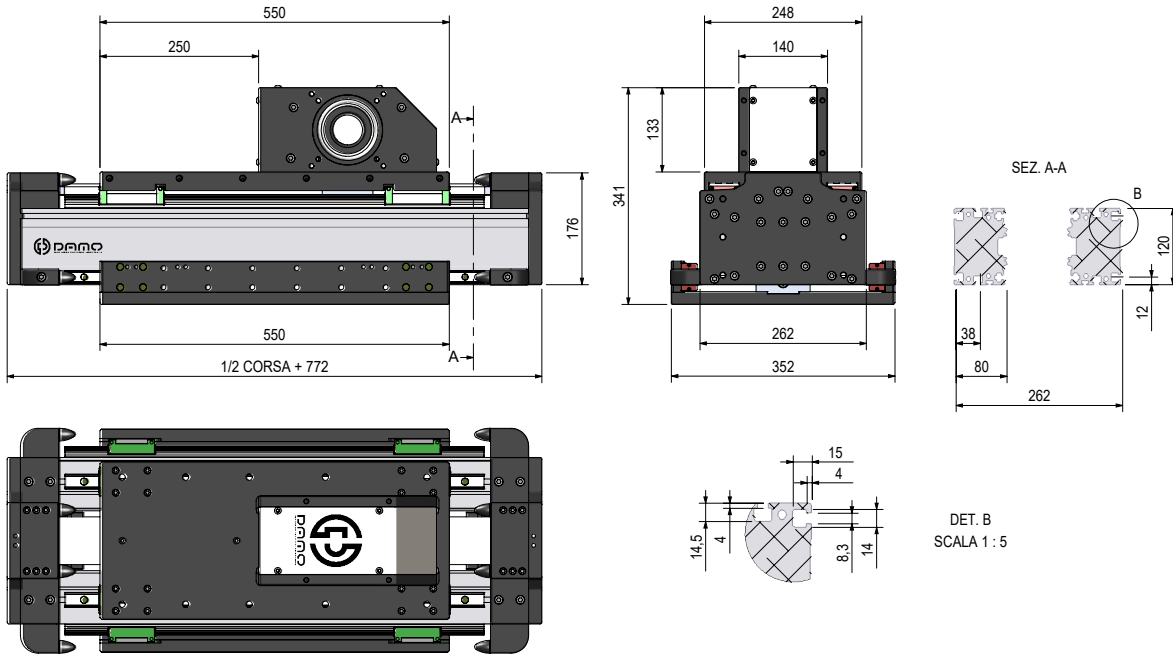

**Carro fisso / Fixed carriage**

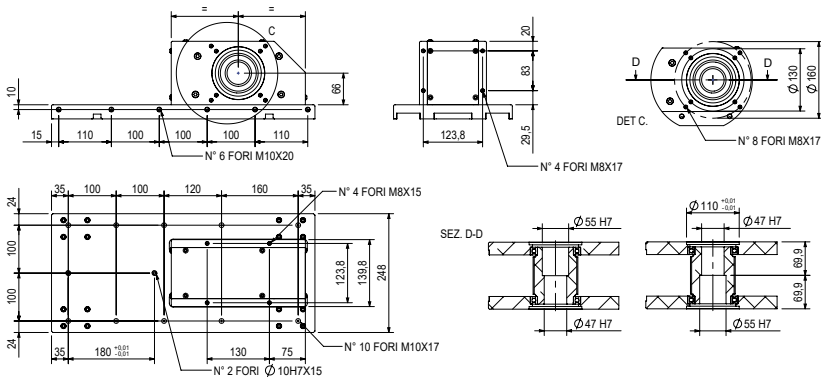

**Tipologia interfaccia riduttore** (2)  
**Gearbox interface type**  
Kit IF40

Configurazioni puleggia  
Pulley configurations

**Carro mobile / Mobile carriage**

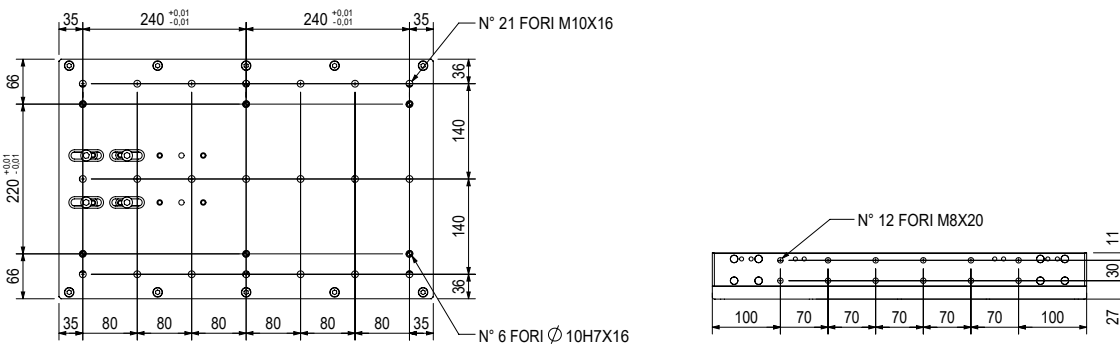

L'ufficio tecnico è a disposizione per la valutazione di applicazioni speciali e per analisi approfondite.  
The technical department is available for the evaluation of special applications and for detailed analysis.



**MODELLO / MODEL**  
**TEL260FBO**

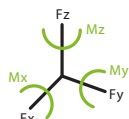
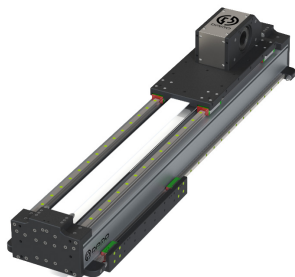

Sono rappresentate le deformazioni massime in condizioni isostatiche, con vincolo rigido e carico all'estremità. La deformazione effettiva dipende dalle condizioni di vincolo e dalla combinazione di carico.

Maximum deflection in an isostatic cantilever loaded condition. Actual strain depends on constraint condition and load combination.

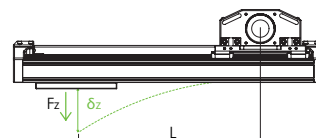

**DEFORMAZIONE ELASTICA / ELASTIC DEFORMATION**

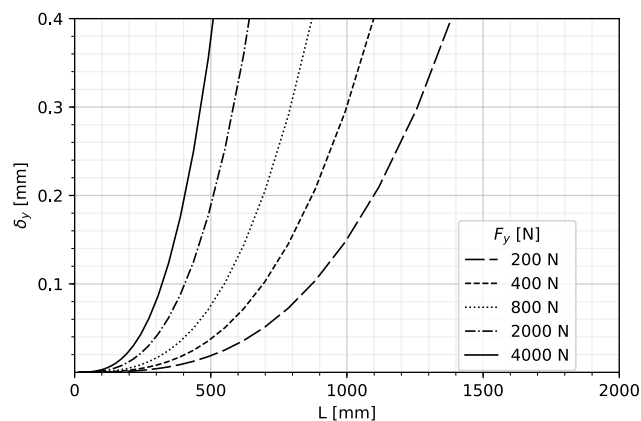
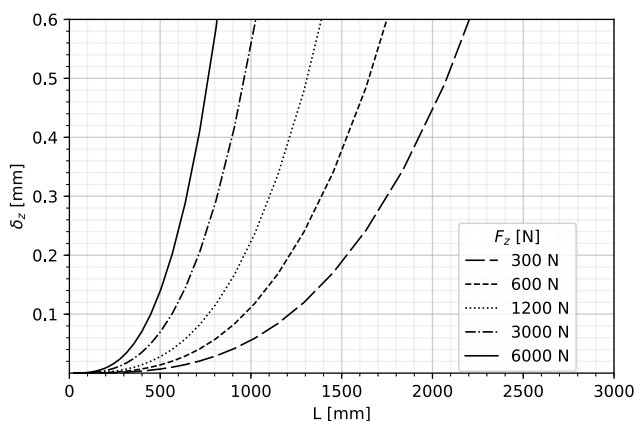

**LIMITI STRUTTURALI / STRUCTURAL LIMITS**

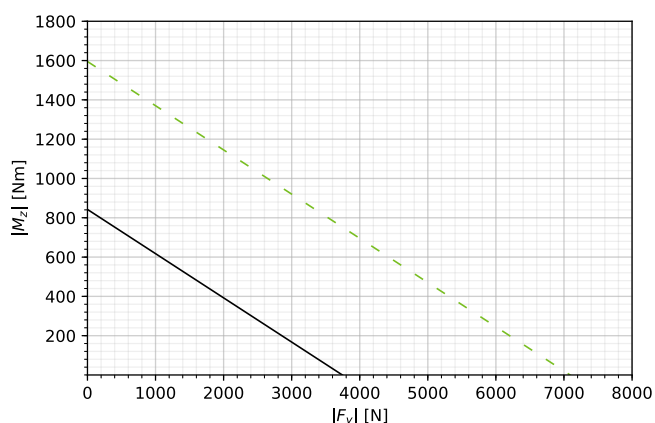
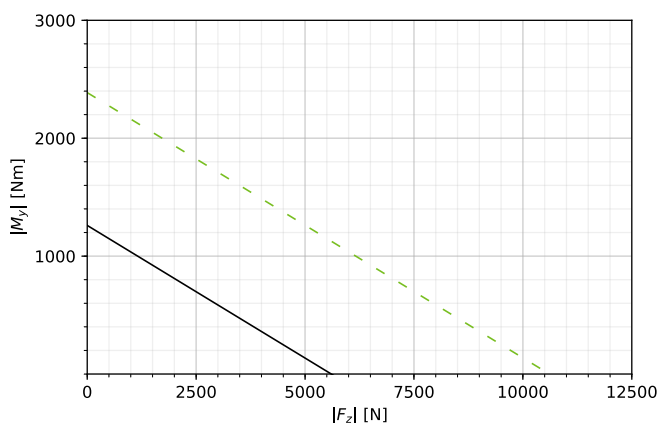

— Limite rottura a fatica: vita stimata superiore ai  $10 \times 10^6$  cicli col 99% probabilità. I grafici non possono essere combinati e valgono per:  $|M_x| \leq 0.1 |M_y|$  e  $|M_x| \leq 0.1 |M_z|$ .  
Fatigue limit: estimated lifetime higher than  $10 \times 10^6$  cycles with 99% probability. Charts cannot be combined and are valid for:  $|M_x| \leq 0.1 |M_y|$  and  $|M_x| \leq 0.1 |M_z|$ .

- - - Arresto d'emergenza max 100 volte nel corso della vita del prodotto.  
Emergency stop max 100 times during service life.

Per casi di sollecitazione composta si faccia riferimento all'ufficio tecnico.  
In case of combined stress contact our technical department.